

INSTRUCTION MANUAL

AUTOMATIC ICE MAKER

REF : ZB-15



Thank you for selecting our ZB Series Automatic Ice-Maker!
To ensure the proper operation of this ice maker, please read the instruction carefully before use and please keep it for inspection in case troubles occur.

English – Original



Index

1. Important safety instructions	3
2. Before putting into use	5
3. Specifications	5
4. Name of the parts	6
5. Operating procedures & maintenance	6
Unpacking your ice maker	6
Connecting your ice maker	6
How to clean	6
Care and maintenance	7
Using your ice maker	7
6. Trouble shooting	8
7. Circuit diagram	9
8. Exploded View and Spare parts list	10
9. Standards and directives	12



1. IMPORTANT SAFETY INSTRUCTIONS

When using electrical appliances, basic safety precautions should be followed to reduce the risk of fire, electric shock, and injury to persons of property. Read all instructions before using any appliance.

- This appliance can be used by children aged from 8 years and above and persons with reduced physical, sensory or mental capabilities or lack of experience and knowledge if they have been given supervision or instruction concerning use of the appliance in a safe way and understand the hazards involved. Children shall not play with the appliance. Cleaning and user maintenance shall not be made by children without supervision.

WARNING : Keep ventilation openings, in the appliance enclosure or in the built-in structure, clear of obstruction.

WARNING : Do not use mechanical devices or other means to accelerate the defrosting process or ice harvesting process, other than those recommended by the manufacturer.

WARNING : Do not damage the refrigerant circuit.

WARNING : Do not use electrical appliances inside the food storage compartments of the appliance, unless they are of the type recommended by the manufacturer.

WARNING : When positioning the appliance, ensure the supply cord is not trapped or damaged.

WARNING : Do not locate multiple portable socket-outlets or portable power supplies at the rear of the appliance.

- This appliance is intended to be used in household and similar applications such as:
 - staff kitchen areas in shops, offices and other working environments;
 - farm houses and by clients in hotels, motels and other residential type environments;
 - bed and breakfast type environments;
 - catering and similar non-retail applications.
- The instructions shall include the substance of the following:
 - Opening the door for long periods can cause a significant increase of the temperature in the compartments of the appliance.
 - Clean regularly surfaces that can come in contact with food and accessible drainage systems.
 - Clean water tanks if they have not been used for 48h; flush the water system connected to a water supply if water has not been drawn for 5 days.
- Fill with potable water only.
- If the supply cord is damaged, it must be replaced by the manufacturer, its service agent or similarly qualified persons in order to avoid a hazard.
- Do not tip over.
- Do not store explosive substances such as aerosol cans with a flammable propellant in this appliance.
- Do not run the power cord carpeting or other heat insulators. Do not cover the cord. Keep cord away from traffic areas, and do not submerge in water.

- Do not use other liquid to make the ice-cube other than water.
- Do not clean your ice maker with flammable fluids. The fumes can create a fire hazard or explosion.
- We do not recommend the use of an extension cord, as it may overheat and become a risk of fire. Unplug the ice maker before cleaning or making any repairs or servicing.
- If the ice maker is brought in from outside in wintertime, give it a few hours to warm up to room temperature before plugging it in.
- The grounding must be good.

The wires in this mains lead are colored in accordance with the following code:

- Live wire (coloured brown) to terminal marked L
- Neutral wire (coloured blue) to terminal marked N
- Earth wire (coloured green and yellow) to terminal marked E

Caution : risk of fire / flammable materials

Refrigerant R600a / R290, this gas is natural gas with high environmental compatibility that is, however, also combustible. When transporting and installing the appliance, care should be taken to ensure that no parts of the refrigerating circuit are damaged. Refrigerant leaked from the refrigerating pipes could ignite, if leaking is detected, to avoid any potential source of ignition (spark, naked flames etc.), please open window or door, and keep good ventilating.



Correct disposal of this product

This marking indicates that this product should not be disposed with other household wastes throughout the EU. To prevent possible harm to the environment or human health from uncontrolled waste disposal, recycle it responsibly to promote the sustainable reuse of material resources. To return your used device please use the return and collection systems or contact the retailer where the product was purchased. They can take this product for environmental safe recycling.





2. BEFORE PUTTING INTO USE

- Before connecting the appliance to the power supply, let the unit stand upright for 4 hours, which will reduce the possibility of the cooling system malfunctioning due to improper handling.
- Clean your unit thoroughly before putting into use. (See "How to Clean")
- Use the parts diagram on page 4 to insure proper positioning of internal components

3. SPECIFICATIONS

Product Description	Ice Maker		
Model No.	ZB-15		
Unit Dimensions	Width	Height	Depth
	360mm	398mm	414mm
Net Weight	17Kg		

4. NAME OF THE PARTS

1. Lid: With a transparent window to allow interior visibility.
2. Inner Liner
3. Ice basket
4. Control Panel: Easy to use , visible functions and 1-touch display setting.
 - A) Select ice cube size
 - B) Start ice making cycle
 - C) Stop ice making cycle
5. Ice pusher
6. Ice Sensor
7. Water Drain Cap: For draining water from water reservoir.
8. Power switch: This switch can control the mains power supply of the appliance.

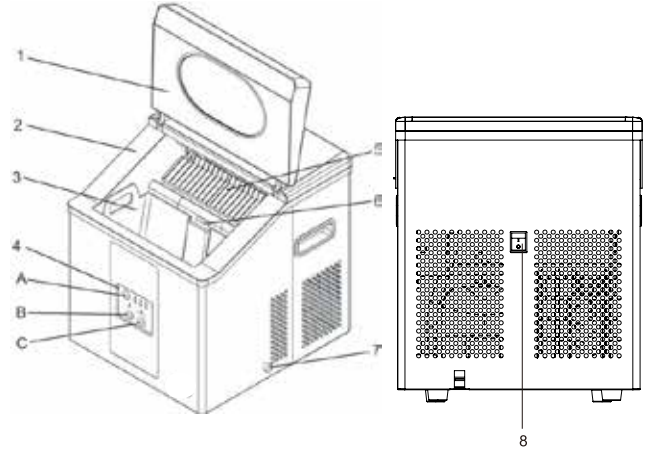

5. OPERATING PROCEDURES & MAINTENANCE

UNPACKING YOUR ICE MAKER

1. Remove all exterior and interior packaging. Check that ice basket and ice scoop is included.
2. Clean the interior with lukewarm water and a soft cloth. Remove the ice basket and wash it in warm water.
3. Find a location for your ice maker that is protected from direct sunlight and other sources of heat (i.e.: stove, furnace, radiator). Place the ice maker on a level surface. Make sure that there is at least 5 inches of space between the back and sides of your ice maker and the wall.
4. Allow 4 hours for the refrigerant fluid to settle before plugging in the unit.
5. The appliance must be positioned so that the plug is accessible.

CONNECTING YOUR ICE MAKER

DANGER

* Improper use of the grounded plug can result in the risk of electrical shock.

1. This unit should be properly grounded for your safety. The power cord of this appliance is equipped with a three-prong plug which connects with standard three prong wall outlets to minimize the possibility of electric shock.
2. Plug your appliance into an exclusive, properly installed, grounded wall outlet. Do not under any circumstances, cut or remove the third (ground) prong from the power cord. Any questions concerning power and/or grounding should be directed toward a certified electrician.
3. This appliance requires a standard AC220-240 volt, 50Hz electrical outlet with three-prong ground.

Before using your ice maker, it is strongly recommended to clean it thoroughly.

The ice maker is not designed to be installed in an outside area such as a garage or a porch. Ambient temperatures of below 7°C or above 32°C will hinder the performance of the appliance.

HOW TO CLEAN

Remove the ice basket.

1. Turn the drain cap counter-clockwise to drain out the water
2. Clean the interior with diluted detergent, warm water and a soft cloth.
3. The outside of the ice maker should be cleaned regularly with a mild detergent solution and warm water.
4. Dry the interior and exterior with a soft cloth.
5. Close the drain cap.
6. When the machine is not in use, open water drain cap to drain water completely from water reservoir.

CARE AND MAINTENANCE

- The ice maker should be cleaned on a regular basis. (See: "HOW TO CLEAN")
- It is necessary to have adequate ventilation space around the ice maker in order to sustain proper performance, dissipation of heat, maintain efficiency, and low power consumption. Clearance of minimum 5 inches should be maintained at the rear and sides of the unit and 8 inches at the top of the unit.
- To attain proper performance, be sure to plug the appliance into a properly grounded AC220-240V/50Hz outlet.
- Do not modify the power cord under any circumstances to allow the unit to be plugged into a non-grounded outlet. To avoid heat damage to the power cord, please ensure that it does not come in proximity or in direct contact with the compressor of the ice maker.
- Please avoid installing the ice maker in a location where the appliance will come in contact with water or moisture to minimize rusting of metal parts.
- The ice maker should not be installed near any heat source or in a location where it will come in direct contact with the sunlight.

USING YOUR ICE MAKER

1. Clean your ice maker thoroughly.

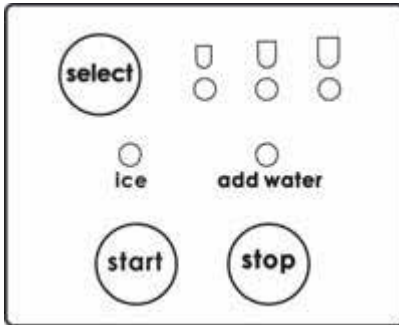

2. Open the lid, remove the ice basket and pour normal tap water into tank.
Keep water level below the bottom of the ice basket.
3. Plug in the unit and the medium ice cubes indicator light will blink.
4. Press "Start" on the control panel to begin the ice making cycle. The medium ice cubes indicator light will light.
5. Select the size of the ice cube by pressing the "Select" button. If ambient temperature is below 15.6°C, it is recommended to select small or medium size to avoid ice sticking together.
6. The ice making cycle lasts 7 to 18 minutes, depending on the ambient temperature and the size of the ice cube selection.
7. While the ice maker is on, if there is low water in the water tank, the ice maker will stop working and the "Add water" indicator light will be on.
Fill the water storage tank with water the ice maker will start to work automatically.
8. The ice maker automatically stops working when the ice basket is full and the "Ice" indicator will be illuminated.
9. Change water in the water reservoir every 24 hours to ensure a reasonable hygiene level.
If unit is not in use, drain all water in the tank reservoir.
10. When reinstalling the basket, push it downward to its original position to ensure the temperature sensor is above the basket so as to ensure the machine works properly.



6. TROUBLE SHOOTING

PROBLEM	POSSIBLE CAUSE	SOLUTION
Ice cubes stick together.	Ice making cycle is too long	Stop the ice maker, and restart when the ice blocks melt.
	Water temperature in inner tank is too low.	Change the water in the reservoir. Use water between 7-32°C
	Leaving ice in the appliance for an extended period of time may result in the appliance recycling the ice by melting it down and making a new batch.	Transfer ready-made ice to another container and store in a cooler or freezer to avoid recycling.
The ice cubes are melting.	Leaving ice in the appliance for an extended period of time may result in the appliance recycling the ice by melting it down and making a new batch.	After extended period transfer ready-made ice to another container and store in a cooler or freezer to avoid recycling.
Ice making cycle is normal but no ice is made.	Ambient temperature or water temperature in inner tank is too high.	Please operate the ice maker below ambient temperature of 32°C and use cold water.
	Refrigerant liquid leakage.	Consult a qualified technician.
	Pipe in the cooling system is blocked.	Consult a qualified technician.

7. CIRCUIT DIAGRAM

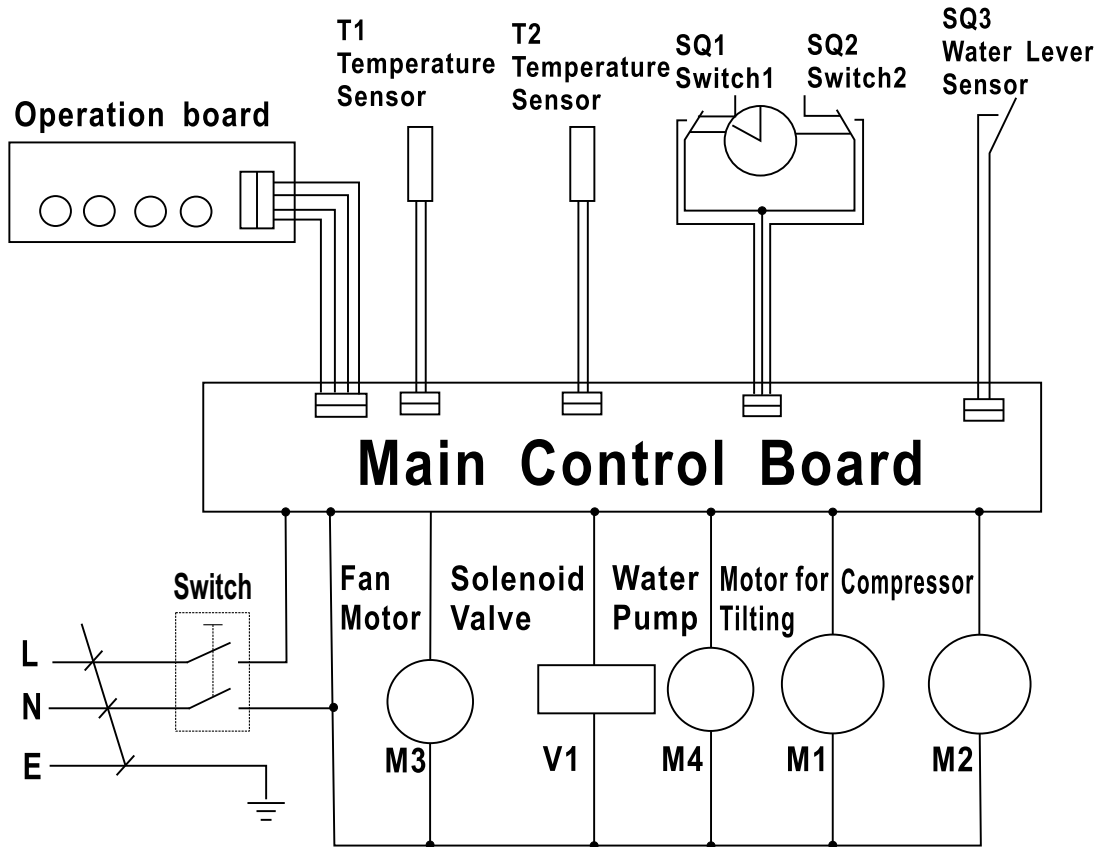

8. EXPLODED VIEW AND SPARE PARTS LIST

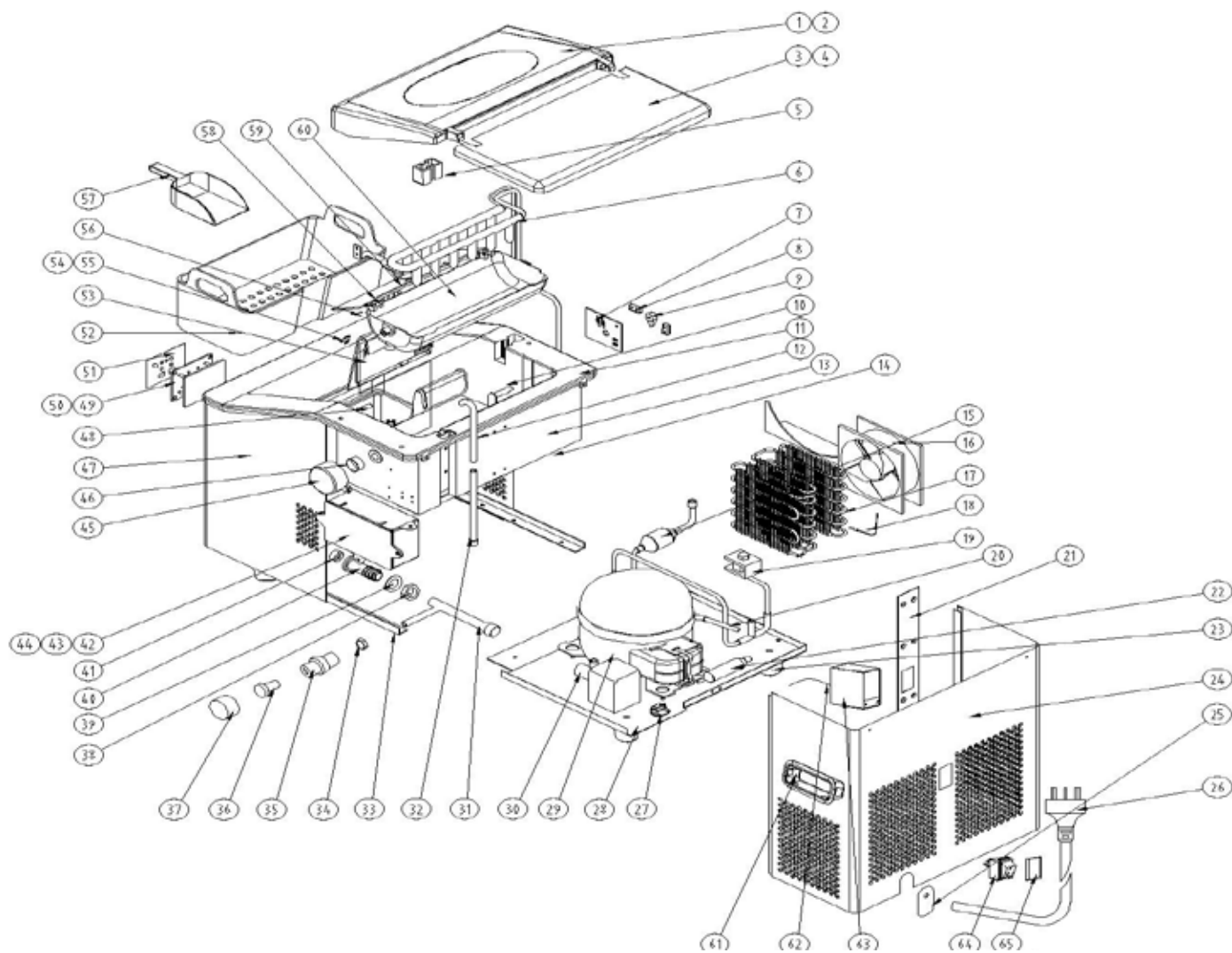

N°	Description	Ref.	Qty
1,2,3,4	Complete Door		1
5	Cover of inner liner		1
6	Evaporator		1
7,8,9,10	Positional switch board		1
11	Inner liner		1
12	water inlet pipe		1
13	heat preservation foam		1
14	downside bottom board		1
15	assembly suction pipe		1
16	condenser fan	ZB-15-5	1
17	condenser		1
18	condenser temperature sensor	ZB-15-6	1
19	electromagnetic valve		1
20	process tube		1
21	back reinforced panel		1
	22	filter	
23	feet		4
24	Back panel		1
26	power cords		1
27	power cords clamp		1
28	Compressor fixing board		1
29	compressor	ZB-15-8	1
30	pump	ZB-15-7	1
31	silica T pipe		1
32	duct		1
33	left and right support		1
34	drainage connector screw		1
38	drainage connector		1

39	seal washer for drainage connector		1
40	drainage pipe		1
41	Strainer		1
42	Main control board	ZB-15-1	1
43	Main control board box		1
44	Main control board cover		1
45	Synchronous motor	ZB-15-2	1
46	Axis cover		1
47	Front Panel		1
48	Water Position Level		1
49	Display Board		1
50 51	Operation Panel Assembly		1
52	Ice Basket		1
53	Draining rack		1
54	Ice-Level Sensor Fixer		1
55	Ice-Level Sensor	ZB-15-3	1
56	axis for ice shovel		1
57	Ice Scoop	ZB-15-4	1
58	clip for Ice Scoop		1
59	ice shovel		1
60	Water Box Assembly		1
61	Recessed Handle		2
62	Switch connection wires		1
63	Switch fixing board		1
64	Power switch		1
65	Waterproof Cap		1
53	Waterproof Cover		

9. STANDARDS AND DIRECTIVES

Meaning of crossed out wheeled dustbin:

Do not dispose of electrical appliances as unsorted municipal waste, use separate collection facilities.

Contact your local government for information regarding the collection systems available.

If electrical appliances are disposed of in landfills or dumps, hazardous substances can leak into the groundwater and get into the food chain, damaging your health and well-being.

When replacing old appliances with new ones, the retailer is legally obligated to take back your old appliance for disposals at least free of charge.

The device complies with current EU standards and directives. If necessary, we will send you the corresponding declaration of conformity.

Packaging disposal

Please separate the packaging materials accordingly and return them to the responsible collection points for recycling and environmental housing.



Device disposal

once the appliance has been used up, dispose of it properly at a collection point for electrical appliances. Electrical appliances do not belong in household waste.

Your responsible administration will inform you about the addresses and opening hours of collection points. This is the only way to ensure that old appliances are properly disposed of and recycled. Thank you very much!

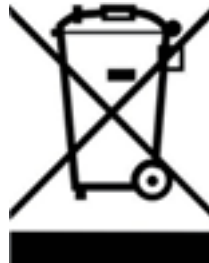



CE